

MCD SERIES

TWIN DISC®

# MARINE CONTROL DRIVE

FAR MORE THAN A MARINE CLUTCH

AN INTRODUCTION TO MCD  
2000, 4000 AND 5000 SERIES

# PRECISE PROPULSION, AGILE MANEUVERING, PLUS FULL AUXILIARY POWER

**Twin Disc originated the clutch-slipping, power-dividing marine control drive (MCD) more than 30 years ago.** The time-tested, field-proven concept has since resulted in a comprehensive lineup of MCDs in Low Dissipation (LD) and High Dissipation (HD) versions across a wide range of power requirements. They offer distinct operating advantages for vessels requiring highly accurate positioning, extreme slow-speed maneuverability and bollard pull scenarios while splitting main engine power to operate auxiliary equipment such as high-power FiFi pumps, cable spools and deck winches.

The newest MCD Series offers a versatile capacity for power dividing as well as slow-speed maneuvering for rugged-duty azimuth-powered tugs, tow boats, firefighting boats, supply vessels, ocean research crafts, ferries and any dynamic positioning applications.

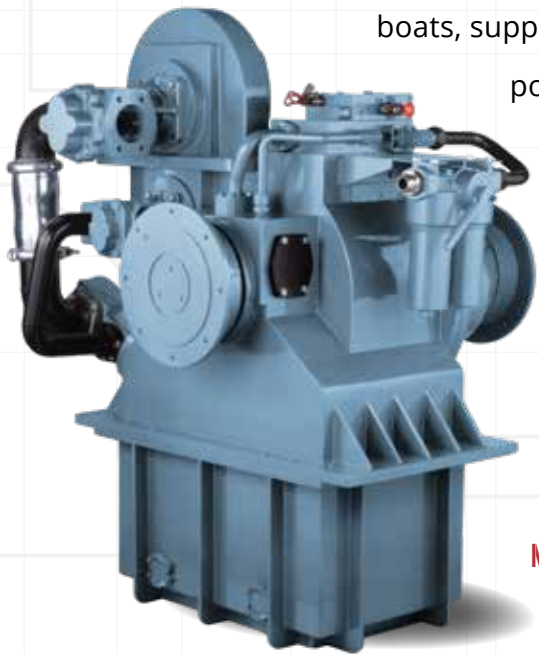

**MCD-4000**

The MCD-2000/4000/5000 series cover extended diesel power requirements from 1680 kW (2280 HP) to 5250 kW (7130 HP) to be distributed between propulsion and auxiliary devices.

The original MCD-3000's formative years were spent in tugs performing precision maneuvering of ships passing through the narrow confines of the Panama Canal.





## TRUE MULTITASKING

A Twin Disc MCD functions as a variable-ratio drive that will match propeller speed to the operator's requirements, while maintaining engine speed at maximum output. It performs as a fixed-ratio drive when continuously underway or in bollard pull conditions.

When used with fixed-pitch azimuth thruster systems, the MCD performs both precise primary propulsion and independent maneuvering control. It permits extraordinarily modulated power, achieving propeller speeds below engine idling speed.

A PTO mounted to the engine front end delivers full engine rpms to be transmitted to fire pumps or other auxiliary equipment—generators, net winches, line spools. For example, an engine front-mounted fire pump can operate at full capacity while the boat maneuvers around the fire scene at virtually any required propeller speed.

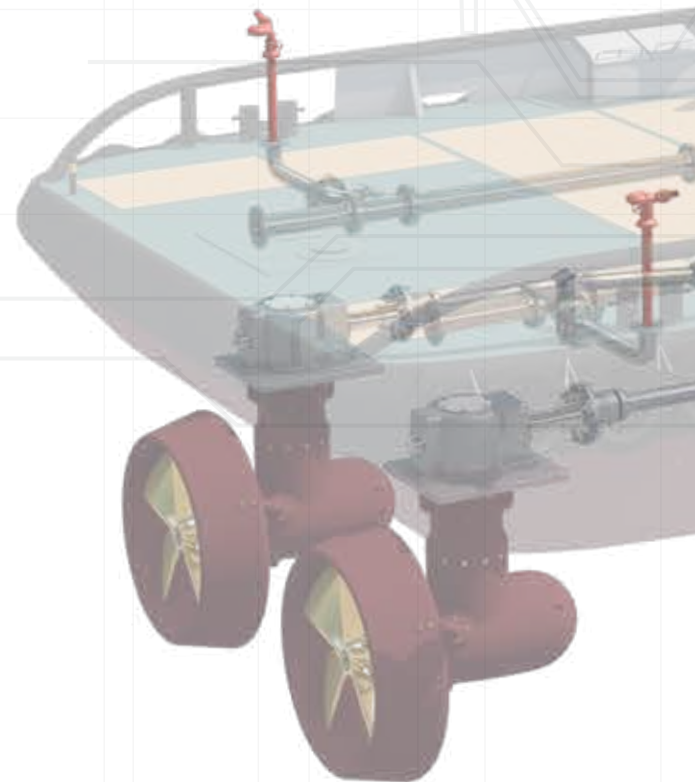

Engines are in idle, MCD and propellers are not engaged.



Propeller speed controlled by engine speed conveyed through MCD's 99% lock-up efficiency for underway propulsion.



MCD modulates engine power to azimuth drives for precise approach and maneuvering.

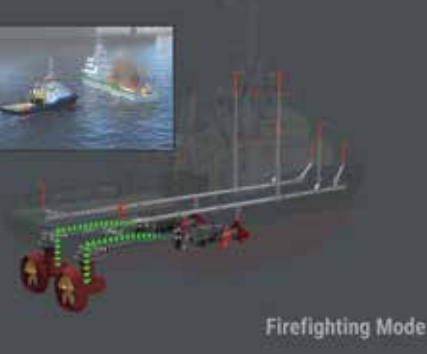

MCD modulates engine power for precise maneuvering while engine front-mounted PTO utilizes full engine RPMs to drive fire pumps.

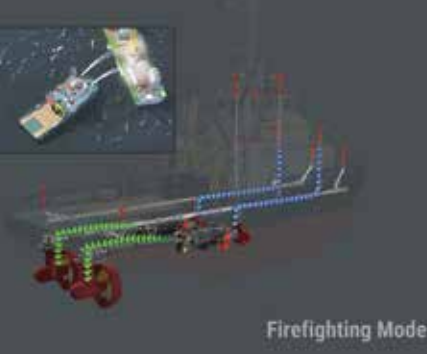

Precision slow-speed maneuvering in FiFi mode, with full pump power.

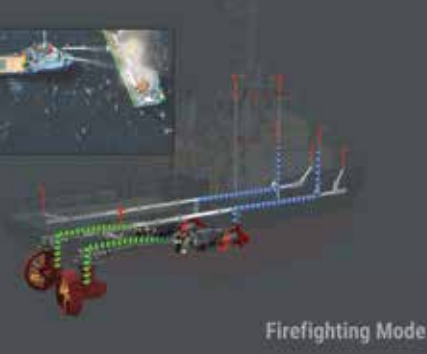

**NORMAL MODE**

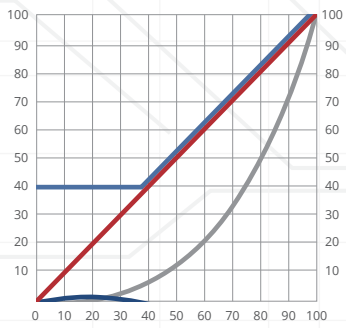

- ENGINE RPM
- PROPELLER ABSORPTION
- MCD OUTPUT RPM
- MCD LOSSES

**FIREFIGHTING MODE**

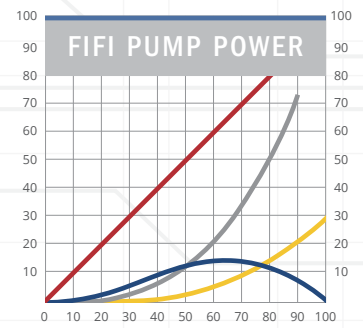

- ENGINE RPM
- PROPELLER ABSORPTION
- MCD OUTPUT RPM
- FIFI PUMP ABSORPTION
- MCD LOSSES

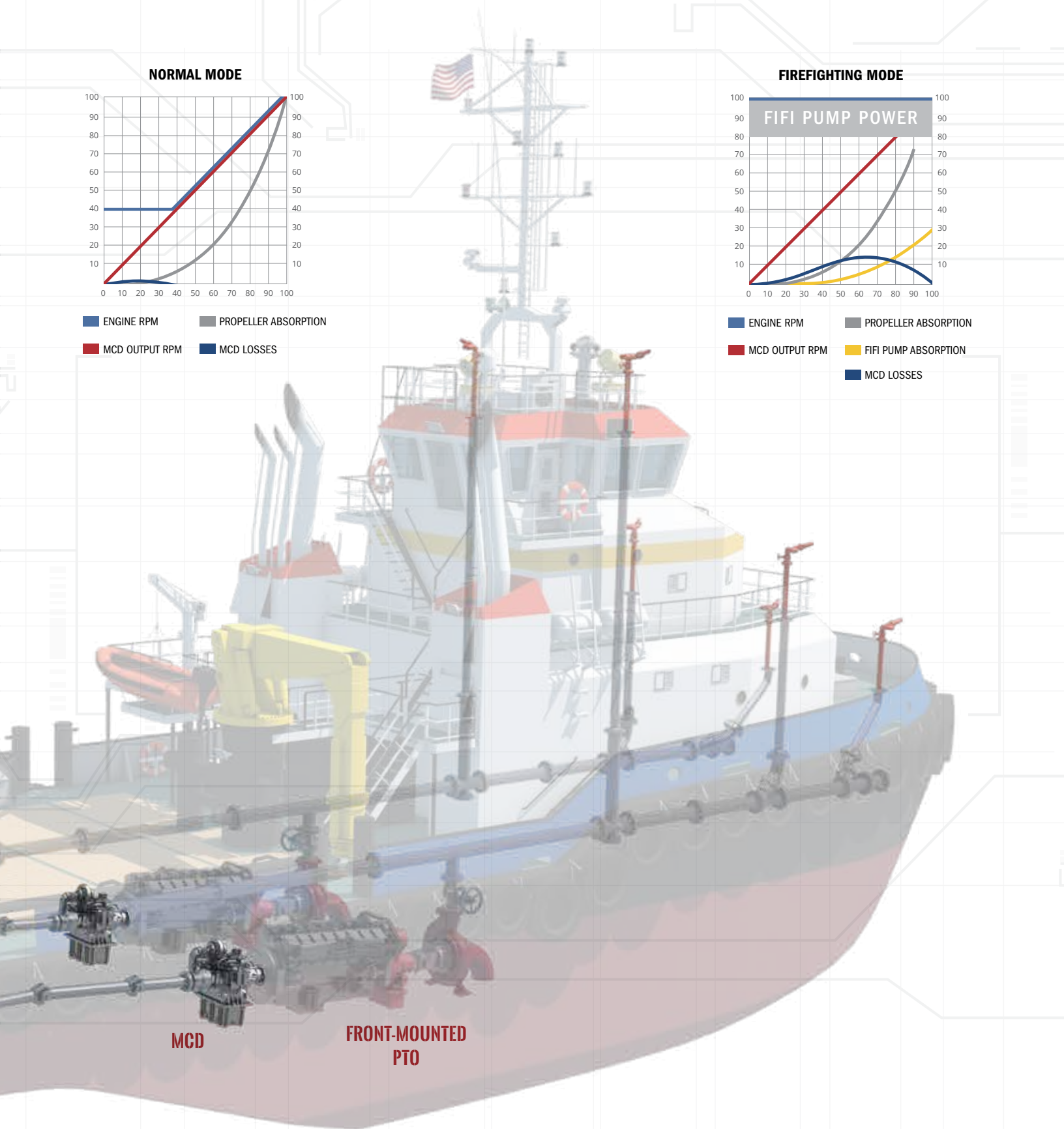

**MCD**

**FRONT-MOUNTED  
PTO**



## THE TECHNOLOGY OF DURABILITY

Unique hydraulic-coupling design allows for intentional clutch slipping to regulate propulsion speed. A stack of friction disks compresses to a greater or lesser degree to achieve desired shaft rpm. Torque is transmitted through a hydro-viscous media. Heat buildup and clutch-plate wear are minimal since the disks are not in contact during the slipping phase. When lock-up is achieved, the input and output speeds are synchronized, reaching virtually full (99%) efficiency, unlike most hydraulic couplings.

## EASIER CLUTCH MAINTENANCE

The MCD is an inboard power-dividing solution versus controllable pitch propellers (CPP), which require dry-docking or divers for maintenance. Dry-docking can be a logistical nightmare and in-water repair by divers poses the risk of oil spillage into the sea. The time-saving servicing of the MCD means your vessel is back on station faster.

## A FULL AND FITTING SOLUTION

LD MODELS	
Model	kW/rpm
MCD-2000-1LD	1.20
MCD-2000-2LD	1.60
MCD-2000-3LD	2.00
MCD-4000-1LD	2.40
MCD-4000-2LD	2.80
MCD-4000-3LD	3.20
MCD-4000-4LD	3.60
MCD-4000-5LD	3.75

Twin Disc's application-proven array of MCDs, including the MCD-2000, 4000 and 5000, allows you to select from multiple versions of each, which means you can choose the MCD to fit your vessel's operating conditions:

1. LD (Low Dissipation) slips up to engine idle speed for maneuvering and dynamic positioning (DP) operation.
2. HD (High Dissipation) slips up to rated engine speed with the capability to dissipate all heat generated by that when power dividing.

HD MODELS		
Model	kW/rpm	Dissipation
MCD-2000-1HD	1.20	100 kW
MCD-2000-2HD	1.60	130 kW
MCD-2000-3HD	2.00	160 kW
MCD-4000-1HD	2.40	190 kW
MCD-4000-2HD	2.80	225 kW
MCD-4000-3HD	3.20	250 kW
MCD-4000-4HD	3.60	290 kW
MCD-4000-5HD	3.75	330 kW
MCD-5000-1HD	3.75	400 kW
MCD-5000-2HD	3.75	450 kW

Slip at any engine speed can be done based upon the specific application criteria. Twin Disc's expert application team will help customize your MCD selection to any desired operator requirement.

Twin Disc MCDs require a much smaller engine-room footprint than multiple engines or motors for propulsion and various deck gear. This multi-purpose value reduces overall equipment and operation costs.



## IT'S ALL HERE

- Smooth, gradual propeller speed change resulting in improved maneuverability
- Safer and easier vessel control during slow-speed maneuvering and docking
- Adjustment of propeller speeds below engine speed rating
- Divides the power from the main propulsion engine to eliminate the need for auxiliary engines
- Delivers an instant response when required
- Bearing calculated for high universal joint angles at maximum power
- Dynamic positioning (DP) capable
- High-power PTO to drive auxiliary equipment
- Emergency "come home" device per classification requirements



## FIND OUT MORE

To select a Twin Disc Marine Control Drive to optimize your vessel's particular productivity, efficiency and performance, contact [Klaus@TwinDisc.com](mailto:Klaus@TwinDisc.com).



**WE PUT HORSEPOWER  
TO WORK®**

THE TWIN DISC FAMILY OF PRODUCTS



**POWER COMMANDER™**



**MASTERTRIM™**

Twin Disc, Incorporated • Racine, Wisconsin 53403, U.S.A. • 262-638-4000 • [www.twindisc.com](http://www.twindisc.com)

UNITED STATES OF AMERICA • AUSTRALIA • BELGIUM • CANADA • CHINA • INDIA • ITALY • NETHERLANDS • SINGAPORE • SWITZERLAND

©2018 TWIN DISC, INC • MCD BROCHURE 10/18