



Twin Disc
Automatic Transmissions Systems.
Superior mobility anywhere on earth.

IT'S BEEN THE FOCUS OF OUR BUSINESS FOR NEARLY A CENTURY. WE'VE BUILT A WORLDWIDE REPUTATION ON OUR ABILITY TO DESIGN, DEVELOP AND MANUFACTURE EFFICIENT, RELIABLE POWER TRANSMISSION SYSTEMS FOR DIVERSE APPLICATIONS.

We understand the varying demands of on/off-road vehicles. Speed. Agility. Brute strength. Rugged durability. Heavy payload. High productivity. We engineer and build transmission systems that combine any or all these criteria.

Off-road roots.

What started in 1918 as a clutch design to make farm tractors more reliable and more productive has grown into a science of all-terrain mobility.

Today, Twin Disc automatic transmission systems mobilize all kinds of vehicles in every region of the globe. Aircraft Rescue Fire Fighting (ARFF) and all wheel drive vehicles rely on Twin Disc equipment to quickly reach accident sites and then "pump and roll" to dispense their extinguishant while maneuvering around the fire. We've designed systems for vehicles that haul 45 tons of equipment over Alaskan permafrost. Oil rig servicing vehicles that traverse Siberian oil fields. Tunnel cleaning machines in the subways of Atlanta.

Forestry service vehicles climbing the mountains of the Northwest. Military transports grinding through desert sand. Construction equipment building a better world.

Twin Disc TD-61-1180 Six-Speed Automatic Transmission.

Emergency One's Titan HPR™ 8x8 with its 1000 hp Detroit Diesel engine and Twin Disc TD-61-2619 automatic transmission system can carry up to 4,227 gallons of water and 405 gallons of foam concentrate and still achieve 50 mph in under 30 seconds.

The Twin Disc Transmission System on this highly mobile IRI International oil well servicing rig controls power to the drive axles and well servicing equipment.



In their Panther series of Aircraft Rescue and Fire Fighting (ARFF) vehicles, Freightliner and Rosenbauer have utilized the latest heavy truck propulsion technologies such as modern 4-cycle, turbocharged diesel engines generating up to 600 horsepower driving through Twin Disc TD61-1180 Six-Speed Automatic Powershift Transmission and Power Divider Systems.



With our unique engineering skill and manufacturing expertise, we deliver systems that offer incomparable effectiveness and efficiency in the most specialized vehicles under the most grueling conditions. Our transmission systems have met the requirements of many global certification societies.

And we still make four wheel drive agricultural equipment more productive.



The new John Deere 9400 four-wheel drive tractor covers a lot of ground with a Twin Disc TD-122-1404 Transmission.

Twin Disc knows power transmissions better than anyone on earth.



The Twin Disc TD-61-1175 Integrated Vehicle Automatic Transmission System provides the driver of this Tatra all-wheel drive truck with superior control under grueling terrain conditions.



An independently mounted Twin Disc integrated vehicle automatic transmission system with patented managed biasing differential eliminates the need for separate transfer case. This remarkable configuration allows flexibility in the weight distribution of the vehicle while smoothly applying power to the wheels.

More control with less effort.

A Twin Disc automatic transmission system lets the vehicle do more of the work so the driver works better. In some cases, "getting there" is the whole objective. Whatever the terrain, whatever the payload, the Twin Disc transmission system offers the performance and reliability to make the trip easier.

The electronic control's microprocessor senses when to shift the transmission without slowing or stopping the vehicle. It knows when to deliver maximum acceleration and traction in all conditions. When to disengage differential lock to prevent over-stressing the axles. And how to prevent the kind of abuse that can shorten component life.

With enough training and experience, the driver could do all of this. But the transmission's microprocessor can do it faster, better, and error-free. That frees the driver to focus on the terrain and the job at hand. It makes the operator and the vehicle safer and more productive. And it protects the vehicle's driveline from harsh shifting errors.

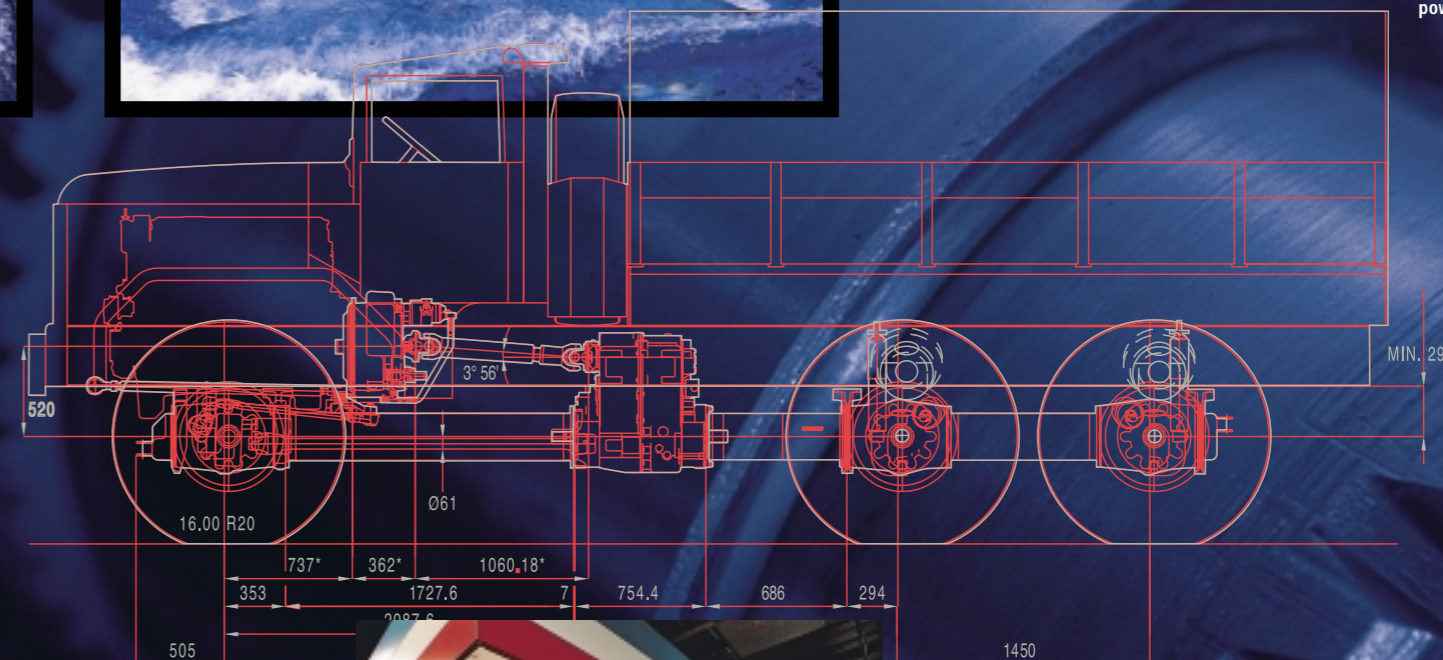

Off-the-shelf or in our head.

Through our experience in engineering power transmission systems for so many different kinds of vehicles, we've developed an impressive line of transmission products and a virtual brain trust of expertise. We probably have an existing transmission system that's suitable for your application. But more importantly, we have the skills and resources to develop one that's ideal.

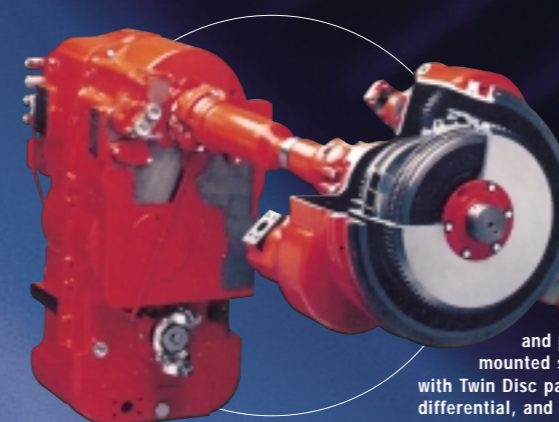
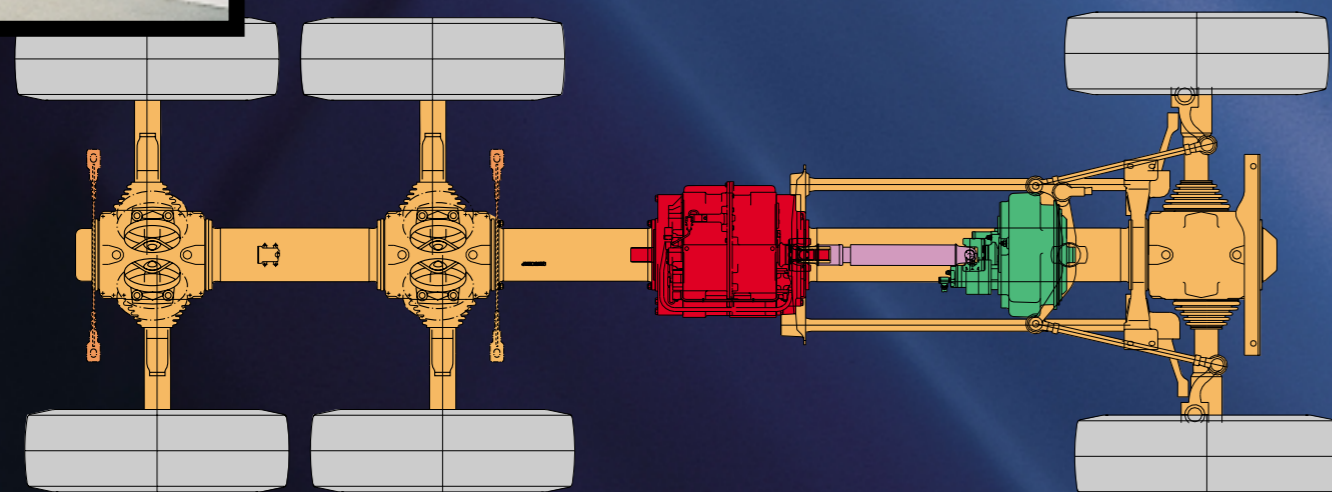

Twin Disc's Automatic Transmission System consists of an engine-mounted modulated clutch torque converter with integral lock-up clutch and power take-off, independently mounted six-speed automatic transmission with Twin Disc patented managed biasing differential, and Twin Disc advanced microprocessor technology.

A Tatra HET (Heavy Equipment Transport) equipped with TD-101-3600 10-Speed Automatic Transmission System performs in rigorous desert conditions.





Matched components. Unmatched performance.

Rather than simply supplying individual components, Twin Disc designs a carefully matched mobility system. Each element of the system coordinates with the others, providing superior performance and reliability.

The system starts with an engine-mounted modulated clutch torque converter. It delivers precisely-controlled power dividing at low speed, while a lockup clutch provides a mechanical connection to engine power at higher speed. An integrated power take-off efficiently splits engine power to drive auxiliary equipment.

An independently-mounted six-speed automatic transmission with an integrated drop-box eliminates the need for a separate transfer case. It includes a patented differential that smoothly applies power to driving wheels.

An advanced electronic control center coordinates communication between the drivetrain elements. It extends service life by protecting the system from driver error and optimizing power relationships between components. With Twin Disc's powerful and programmable microprocessor, we can customize the system's operation to meet your specific operating requirements.



This 115-ton (gvw) Liebherr MPC (Multi-Purpose Carrier) 12x12 is equipped with an MTU 905-horsepower engine and a Twin Disc TD101-3600 10 Speed Automatic Transmission with FLW-1854-1 Torque Converter and an ETA28N Electronic Control.

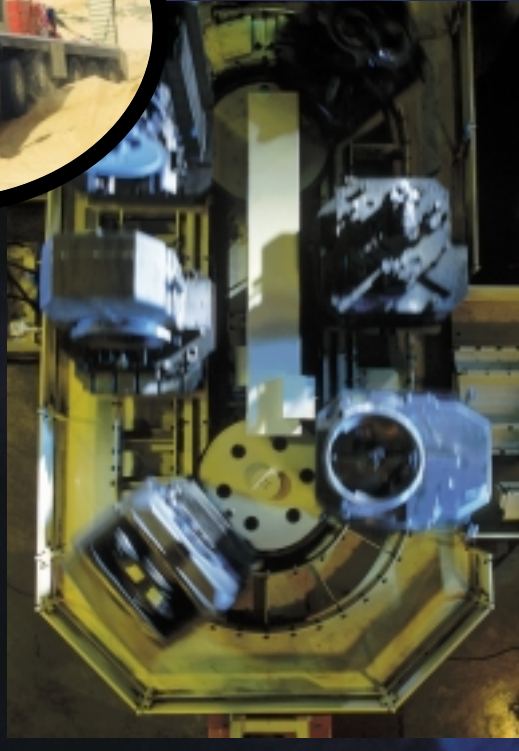

Then the design must prove itself in a fully-automated test facility. We can run high-speed endurance tests around the clock, speeding development and response time.

A wholly-owned subsidiary, TD Electronics, Inc., supplies all electronic components for Twin Disc products. We control every stage of electronic system development, from concept to installation.

Twin Disc's flexible, cell-based manufacturing facilities can adapt quickly to produce new products as they're developed. We design and manufacture all components in-house, including shafts, gears and housings. Our manufacturing centers in the USA and Europe are certified under the provisions of ISO 9001.

Our regional sales offices and vast distribution network support Twin Disc equipment in service all over the world. With a corporate presence in every major market region, Twin Disc can put engineering and service expertise on location virtually anywhere.



Perfecting the new solution.

Twin Disc's system approach has proven itself over and over in so many different types of vehicles. Our systems are specialized enough to excel in the most unique applications. And flexible enough to be adapted to new, experimental vehicles. We're constantly breaking new ground.

The total package.

We are able to successfully build systems for so many diverse applications because we control every step of system development, from research to engineering to manufacturing to sales and service.

Twin Disc has the engineering experience to anticipate the power transmission challenges a vehicle will face, and the resources to develop a specific product or system solution to meet those challenges. Using computerized systems modeling, torsional vibration analysis and finite

element analysis, we can design your system for optimum efficiency.



A Sides 2000 13R CFR delivers lifesaving performance fast with its Twin Disc TD-61-2619 Automatic Transmission System with 8-MLW-1856 Torque Converter turning the 750 horsepower from the Detroit Diesel engine into propulsion and pumping.



Twin Disc, Incorporated
1328 Racine Street
Racine, Wisconsin 53403, USA
414-638-4000/414-638-4482 (fax)

<http://www.twindisc.com>

Singapore Australia Spain Italy Twin Disc
International S.A.
1400 Nivelles, Belgium

Bulletin 830A 6/00-5M
©2000, Twin Disc, Incorporated
Printed in United States of America